

Yongmao ST 55/13 A

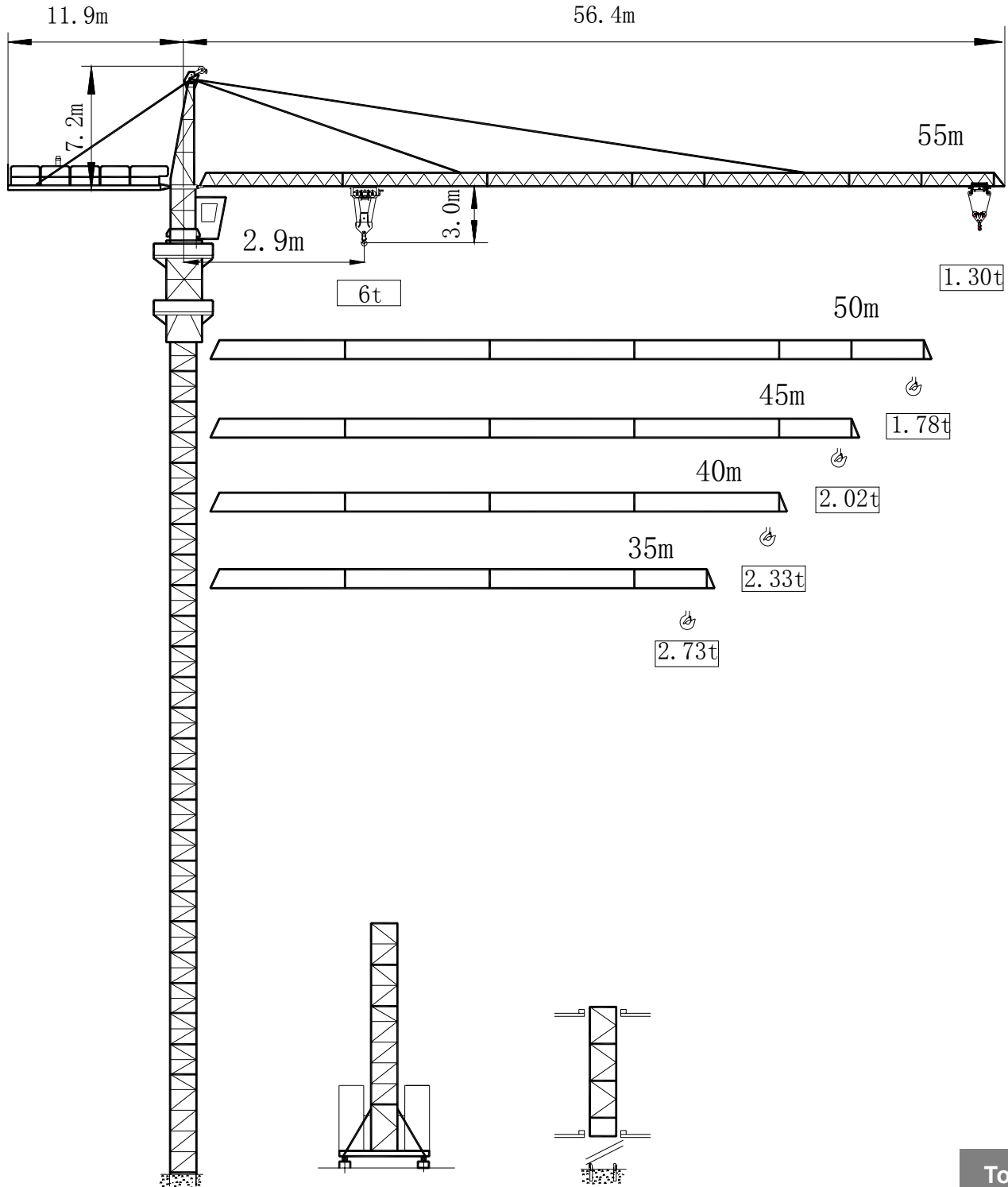

Topkit

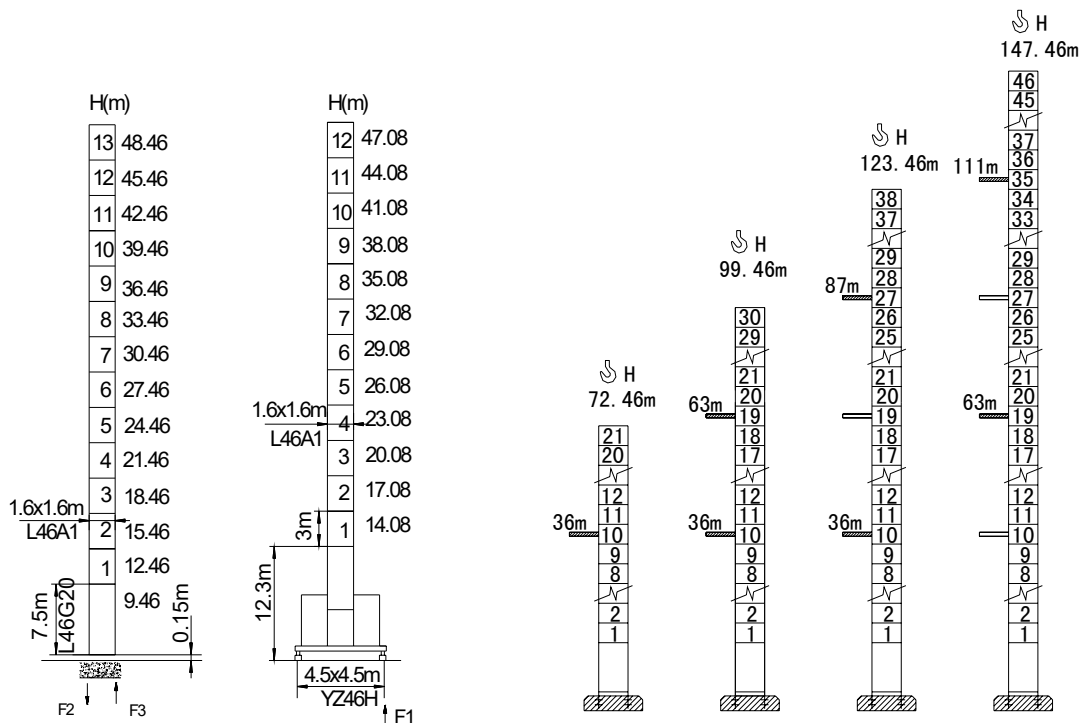

	●	■		●	■	
F2	92t	154t		F1	65t	131t
F3	109t	142t				
⊗	43t			⊗	46t	

- 工作狀態支反力 In Service
- 非工作狀態支反力 Out of Service
- ⊗ 整機自由高度重量 (不含平衡重及壓重重量)
Crane Weight Without Load, Ballast With Longest Jib And Max. Height

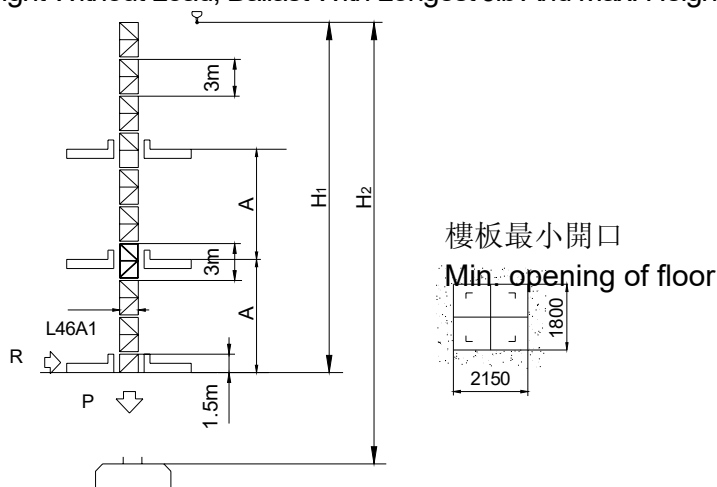









內爬塔機參數 Specification Of Internal Climbing Crane

塔身節數量 Number of mast	臂長 Jib length	H1	A	P(t)	R(t)
8	50m	26.8	7~11m	53.6	17.8





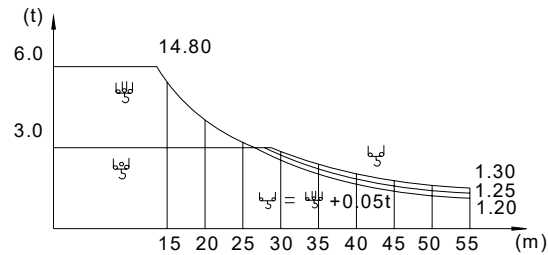

- H1** 由固定角鋼底部算起的高度 Height from fixed angle iron
- H2** 起升機構允許最大高度 Max. height which the hoisting winch permits

起重量載荷表 loading capacity

R	吊钩 Hook	倍率 Fall	R(max) m	C(max) t	15	20	25	30	35	40	45	50	55
55		IV	14.80	6.0	5.91	4.24	3.26	2.62	2.17	1.84	1.58	1.37	1.20
		II	27.21	3.0	3.00	3.00	3.00	2.67	2.22	1.89	1.63	1.42	1.25
55		II	27.74	3.0	3.00	3.00	3.00	2.74	2.28	1.94	1.68	1.47	1.30
		IV	17.17	6.0	6.00	5.04	3.90	3.15	2.62	2.23	1.92	1.68	
50		II	31.70	3.0	3.00	3.00	3.00	3.00	2.67	2.28	1.97	1.73	
		II	32.25	3.0	3.00	3.00	3.00	3.00	2.73	2.33	2.02	1.78	
45		IV	17.18	6.0	6.00	5.04	3.90	3.15	2.62	2.23	1.92		
		II	31.74	3.0	3.00	3.00	3.00	3.00	2.67	2.28	1.98		
45		II	32.25	3.0	3.00	3.00	3.00	3.00	2.73	2.33	2.02		
		IV	17.19	6.0	6.00	5.05	3.90	3.15	2.62	2.23			
40		II	31.74	3.0	3.00	3.00	3.00	3.00	2.67	2.28			
		II	32.25	3.0	3.00	3.00	3.00	3.00	2.73	2.33			
35		IV	17.20	6.0	6.00	5.05	3.91	3.16	2.63				
		II	31.77	3.0	3.00	3.00	3.00	3.00	2.68				
35		II	32.25	3.0	3.00	3.00	3.00	3.00	2.73				



塔機機構主要性能參數 Main Specifications

名稱 Items	機構代號 Mechanism	工作速度 / 起重量 Speed/ Hoist weight				容繩量 Rope capacity	電動機 Motor Kw
		m/min	t	m/min	t		
提升 Hoisting 	24PQC15					400m >400m*	24/24/5.5
		0-8.5	3	0-4.2	6		
		0-40	3	0-20	6		
	0-80	1.5	0-40	3			
變幅 Trolleying 	DTC55	0-57 m/min				280m >280m*	24/24/5.4
		0-8.5	3	0-4.2	6		
		0-40	3	0-20	6		
回轉 Slewing 	RTC95	0-0.7rpm				1x5.5	95Nm
	YMD50	0-0.7rpm					
行走 Traveling 	RT	12.5-25m/min				2x3.4	

CASA MATRIZ: Camino Coquimbo N°16.776, Condominio Industrial los Libertadores, Colina Santiago, Chile.

Tel: 562 2484 2100

LA SERENA: Parcela 110, Lote 3A, Vegas Norte.

CONCEPCIÓN: Camino a Coronel km. 11, Parque San Pedro, Módulo 15 N°6060, San Pedro de la Paz.

PERÚ ETAC: Avenida el Sol MZ J1 Lt B1 Villa el Salvador Lima.

COLOMBIA COLGRÚA: Calle 19 # 50-13, Bogotá.

TELÉFONO EMERGENCIAS

+56 9 9228 3427